

THRU-THE-WALL AIR CONDITIONERS



F R I E D R I C H

1 8 8 3

Best Hotel Products
PTACs • MATTRESSES • TVs • FURNITURE

www.BestPTAC.com
847-749-0800



26" AND 27" SLEEVES. IDEAL for NEW CONSTRUCTION, RETROFITS and REMODELS.

27" SLEEVE

Ideal for new construction, and as a high efficiency replacement in retrofits and remodels



Features

- High efficiency operation saves on energy costs
- Residential/commercial applications
- Heat pumps and electric heat models
- Mounts flush with the exterior wall for a neat appearance
- Ideal for thicker wall installations, where side fins don't fit
- A high efficiency replacement for 27" sleeves including Fedders A and B*. Sleeve measures 27" W x 16 3/4" H
- Easy-to-reach, top mount controls
- Three-speed fan
- Efficient rotary compressor
- Easy-to-clean filter
- Auto restart



Digital Control Features

- Remote control
- 24 hour programmable timer
- Money Saver® setting saves money by conserving energy
- Smart Fan auto-adjusts fan speed to maintain desired temperature
- Auto-memory backup saves settings should power be interrupted

WallMaster®

COOLING	HEATING
7,800-14,500 BTU/h Up to 9.9 EER	7,300-11,000 BTU/h

Unit is shown installed in WSD sleeve (sold and shipped separately)
*Installation in Fedders B sleeve requires a baffle kit. See BAK accessory under accessories.

Sleeve Dimensions	Friedrich WSD Sleeve	Fedders A Sleeve	Fedders B Sleeve*
Height (inches)	16 3/4	16 3/4	16 3/4
Width (inches)	27	27	27
Depth (inches)	16 3/4	16 3/4	19 3/4

26" SLEEVE

Universal fit for easy replacement in existing 26" sleeves



Features

- Rotary compressors provide quiet, dependable performance
- Six-way air flow control
- Stale air exhaust
- Auto restart
- Washable/reusable filter
- Seacoast protection



Digital Control Features

- 12 hour programmable timer
- Money Saver® setting saves money by conserving energy

Uni-Fit®

COOLING

HEATING

8,000-13,000 BTU/h
Up to 9.6 EER

3,850-11,200 BTU/h

Sleeve Dimension	Friedrich USC Sleeve	Amana	Carrier (515 Series)	Fedders/ Emerson/ Friedrich WSD	Emerson/ Fedders	GE/ Hotpoint	Whirlpool	White-Westinghouse/ Frigidaire/ Carrier (52F Series)
Height (inches)	15 1/2	15 5/8	16 7/8	16 3/4	15 3/4	15 5/8	16 1/2	15 1/4
Width (inches)	25 7/8	26	25 3/4	27	26 3/4	26	25 7/8	25 1/2
Depth (inches)	16 3/4	16 7/8	18 5/8	16 3/4 or 19 3/4	15	16 7/8	17 1/8 or 23	16, 17 1/2 or 22

Units are shown without USC sleeve (USC sleeves sold and shipped separately)

WallMaster® 27" Sleeve Exterior Grilles



WSD Sleeve
Standard Grille - Ships
with sleeve. Galvanized
steel weather panel also
ships with sleeve.



WSD Sleeve
Optional Architectural Grille- AG

IMPORTANT:
Operating the air
conditioner with incorrect
rear grille or without
Baffle Adapter Kit (on
19 3/4" deep sleeve)
will recirculate discharge
air and cause compressor
overload to trip.

CORRECT Vertical Louvers

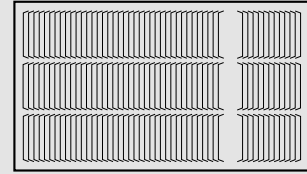

INCORRECT Horizontal Louvers

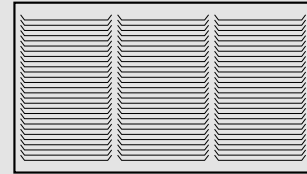

Installation Accessories (27" sleeve models only)

DK / Drain Kit

Installed at the back of the unit and allows for attachment to permanent condensate disposal system, if disposal is necessary or desired.

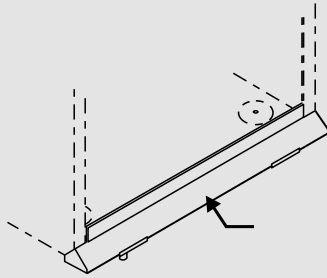

SB / Sub Base

Used as a base for the unit when it is desired to place the cord and receptacle within the installation, or simply as a base for the unit when mounted low in the wall.

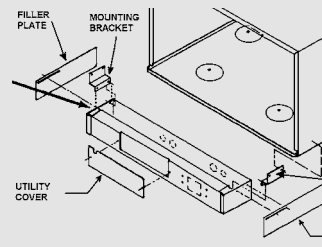

IDK / Internal Drain Kit

New construction applications where a condensate drain system has been built into the wall interior.

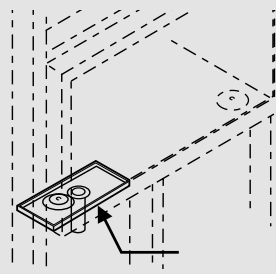

BAK / Baffle Adapter Kit

Necessary when installing in a sleeve deeper than 16 3/4" deep, such as Fedders B sleeve (19 3/4" deep).

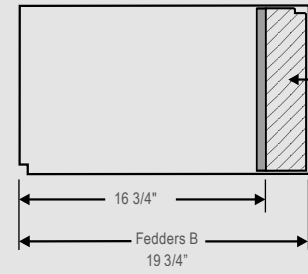

Uni-Fit® 26" Sleeve Exterior Grilles



USC Sleeve
Standard Grille



Sleeve shown with
Replacement Grille

STANDARD GRILLE - Ships with USC sleeve
Expanded aluminum grille designed for use with USC sleeve.

REPLACEMENT GRILLE - Ships with US/UE chassis
High-tech plastic for use on existing sleeves without any grille.

IMPORTANT:
When installing into an existing sleeve, consult
Installation Section of your Installation/Operation Manual
to determine whether or not the grille needs to be
replaced and/or a baffle adapter should be used.

Sleeve/Chassis Dimensions

Model	Height	Width	Depth	Depth with Front	Minimum Extension Into Room	Minimum Extension Outside	Thru-the-wall Finished Hole		
							Height	Width	Max. Depth
WALLMASTER									
WSD Sleeve	16 3/4"	27"	16 3/4"	23"	7 1/2"	9/16"	17 1/4"	27 1/4"	15 5/16"
Chassis	15 3/4"	26 1/2"	21"	22"	-	-	-	-	-
UNI-FIT									
USC Sleeve	15 1/2"	25 7/8"	16 3/4"	20 1/2"	-	1/2"	15 3/4"	26 1/8"	16 1/4"
US Chassis	14 3/8"	24"		20 1/8"	3 3/4"	-	-	-	-
UE Chassis	14 3/8"	24 5/8"		19 5/8"	3 1/2"	-	-	-	-

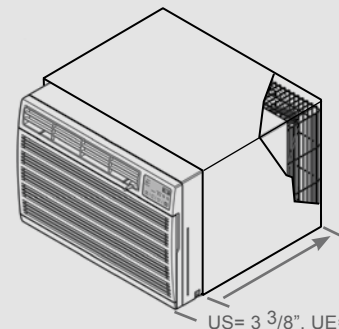

IMPORTANT:
US chassis w/front fully installed into USC sleeve
extends into room 3 3/8". UE chassis w/front fully
installed into USC sleeve extends into room 2 7/8".

IMPORTANT: Sleeves are sold and shipped separately to accommodate new construction and replacement requirements

Commercial & Residential Applications



THRU-THE-WALL units mount flush with exterior walls for a sleek appearance, as well as unobstructed window views.

(Wallmaster WSD sleeve shown with architectural grille. Uni-fit grille has different appearance.)



When should you install a solid side sleeve?

SOLID SIDE wall sleeve allows for installation in thick exterior walls where the installation of room air units with side vents would effect performance and may even void the warranty.

ROOM AIR CONDITIONER

Blocked side vents restrict air flow

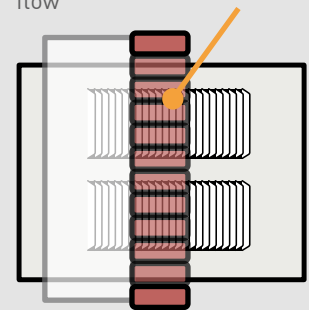

FRIEDRICH THRU-THE-WALL

Solid-side sleeve (no side vents) can be installed flush with exterior wall.

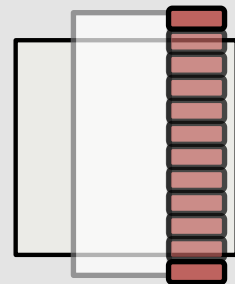

Specifications



Model	Cooling Capacity Btu	Heating Capacity Btu	Volts Rated	Cooling Amps	Cooling Watts	Heating Amps	Heating Watts	Energy Efficiency Ratio EER	Estimated Yearly Operating Cost	Moisture Removal Pints/HR	Room Side Air Circulation CFM	Sleeve	Net Weight Lbs
WALLMASTER													
<i>Cool only</i>													
★ WS08C10	7800	NA	115	7.1	788	NA	NA	9.9	†	1.2	250	WSD	93
★ WS10C10	9700	NA	115	10.0	1032	NA	NA	9.4	\$82	2.4	257	WSD	103
★ WS12C10	11900	NA	115	11.8	1266	NA	NA	9.4	\$101	3.3	295	WSD	112
★ WS10C30	9500/9200	NA	230/208	4.5/4.7	989/958	NA	NA	9.6/9.6	\$79	1.5	300	WSD	101
★ WS13C30	12600/12300	NA	230/208	6.3/6.7	1340/1309	NA	NA	9.4/9.4	\$107	3.6	290	WSD	109
★ WS15C30	14500/14500	NA	230/208	8.3/8.2	1706/1706	NA	NA	8.5/8.5	\$136	4.2	290	WSD	119
<i>Heat Pumps</i>													
★ WY09C33	9300/9000	7300/7300	230/208	4.4/4.7	989/957	3.8/4.0	839/793	9.4/9.4	\$79	2.1	250	WSD	103
★ WY12C33	12000/11800	9350/9200	230/208	6.1/6.4	1395/1372	4.8/5.1	1062/1010	8.6/8.6	\$111	2.6	275	WSD	111
<i>Cool with Electric Heat</i>													
★ WE10C33	9500/9200	11000/9100	230/208	4.5/4.7	989/958	16.0/14.7	3550/2950	9.6/9.6	\$79	1.5	300	WSD	121
★ WE13C33	12600/12300	11000/9100	230/208	6.3/6.7	1340/1309	16.0/14.7	3550/2950	9.4/9.4	\$107	3.6	290	WSD	107
★ WE15C33	14500/14500	11000/9100	230/208	8.3/8.8	1706/1706	16.0/14.7	3550/2950	8.5/8.5	\$136	4.2	290	WSD	116
UNI-FIT													
<i>Cool Only</i>													
★ US08C10	8000	-	115	7.5	830	-	-	9.6	\$66	2.2	260	USC	73
★ US10C10	9800	-	115	9.6	1040	-	-	9.4	\$83	3.2	285	USC	78
★ US12C10	11500	-	115	11.2	1220	-	-	9.4	\$97	3.8	290	USC	80
★ US10C30	10000/9800	-	230/208	4.7/5.2	1060/1040	-	-	9.4/9.4	\$85	3.2	285	USC	78
★ US12C30	11500/11200	-	230/208	5.6/6.0	1220/1190	-	-	9.4/9.4	\$97	3.8	290	USC	80
★ US14C30	13000/12600	-	230/208	7.0/7.5	1530/1480	-	-	9.4/9.4	\$122	4.0	310	USC	87
<i>Cool with Electric Heat</i>													
★ UE08C13	8000	3850	115	7.5	830	10.7	1230	9.6	\$66	2.2	260	USC	73
★ UE10C33	10000/9800	11200/9200	230/208	4.7/5.2	1060/1040	15.3/14.0	3500/2900	9.4/9.4	\$85	3.2	285	USC	78
★ UE12C33	11500/11200	11200/9200	230/208	5.6/6.0	1220/1190	15.3/14.0	3500/2900	9.4/9.4	\$97	3.8	290	USC	80

WallMaster Heat Pump heating information (shown in red) indicates heat pump heating performance. WallMaster Electric Heat heating information (shown in red) indicates electric heat strip performance. For WallMaster Heat Pump electric heating performance refer to corresponding WallMaster Electric Heat model.

WALLMASTER HEAT PUMP

HEATING PERFORMANCE: Change-over from heat pump operation to resistance operation on models indicated is automatic at a preset outside ambient temperature of approximately 35°F.

Calculate the heat loss of the space to be heated. As long as the heat loss does not exceed the resistance heating capacity rating of the unit, the heating performance will be satisfactory.

Note: all models will produce condensate. If condensate disposal is desired, an optional drain kit is available.

DEFROST CONTROL: Initiated at 30°F (outdoor coil temperature) and terminated at 43°F (outdoor coil temperature). During defrost, the compressor stops and the electric heat starts, then operates with the fan to maintain indoor comfort. Below 43°F, the unit remains in electric heat mode.

DEFROST DRAIN: Drain automatically opens at approximately 50°F to prevent condensate from freezing inside drain pan.

Plug Face/ Circuit Rating

WallMaster Model Number	Uni-Fit Model Number	Circuit Rating Breaker or T-D Fuse	Plug Face (NEMA#)	Power Cord Length (ft.)	Wall Outlet Appearance
WS08C10, WS10C10, WS12C10	US08C10, UE08C13 US10C10, US12C10	125V - 15A	5 - 15P	6	
WS10C30, WS13C30, WS15C30	US10C30, US12C30, US14C30	250V - 15A	6 - 15P	4	
WE10C33, WE13C33, WE15C33, WY09C33, WY12C33	UE10C33, UE12C33	250V - 20A	6 - 20P	4	

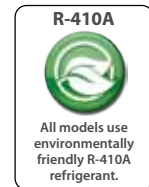

Power cords are located on front left of WallMaster models and on front right of Uni-Fit models.

Due to continuing research in new energy-saving technology, specifications are subject to change without notice. As an ENERGY STAR® partner, Friedrich Air Conditioning Co. has determined that the selected ENERGY STAR® models meet the ENERGY STAR® guidelines for energy efficiency.

Estimated yearly operating cost based on a 2007 national average electricity cost of 10.65 cents per kWh. † The estimated yearly operating cost of this model was not available at the time the range was published.



FRIEDRICH

Best Hotel Products
PTACs • MATTRESSES • TVs • FURNITURE

www.BestPTAC.com - www.BestHotelFurniture.net
Call For Hospitality Industry Pricing: 847-749-0800